

Power Factor Correction (PFC) Modules

General Description

The PFC Modules are power factor corrected AC-DC converters. They accept a wide range AC input and convert it to 380VDC output. This conversion is made with the constraint that the input power factor must be near unity. Unity power factor requires that the instantaneous input current be proportional to the instantaneous input voltage. In other words, the PFC module looks like a resistive load to the AC power source. The PFC modules allow designers to meet the European power factor regulations set forth in the IEC Specification IEC 1000-3-2.

This application note discusses PFC operation and features, basic PFC application, and multiple PFC systems. It also touches lightly on some possible applications as well as some precautions that should be observed when designing with and using PFC modules

PFC Operation and Features

The PFC modules incorporate a 140kHz boost converter with a solid state switch for active inrush and short circuit current limiting (See *Figure 24a*). The boost topology was chosen, in part, because its output voltage is higher than its input voltage. Therefore, if the output voltage is high enough to operate off the highest utility (input) voltage, the module can then operate from any utility voltage. The highest utility voltage is 264 VAC which has a peak voltage of 373V. For the PFC module to have a truly “universal” input range, the regulated output voltage must be higher than 373V. RO PFC modules meet this requirement with a nominal output voltage of 380V.

There are two characteristics of the boost topology DC-to-DC converter that significantly affect the PFC module design and application. The first characteristic is that the output is not isolated from the input. Therefore the high voltage bus is considered to be a “primary

circuit” by the safety agencies. All of the safety regulations that apply to primary circuits also apply to the outputs and status signals of the PFC module. It also means that grounded instruments, such as an oscilloscope, can’t be connected to the module’s pins unless isolation is added to the system.

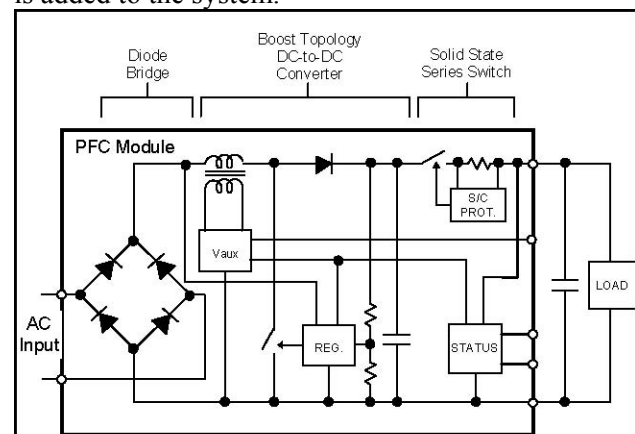

Figure 24a A Simplified PFC Diagram showing the three main sections of the PFC.

Do not connect the output or status pins to earth ground either intentionally or accidentally (e.g. with a scope probe ground lead) unless proper precautions have been taken.

Consider using an isolation transformer for testing purposes.

The second characteristic of boost converters is that they are not inherently short circuit protected or current limited. Astrodyne has added a solid state series switch in the output stage of the PFC module (See *Figure 24a*) to protect the module and load from high surge currents at turn-on. The series switch also protects the module from excessive current due to a shorted or malfunctioning load. When active, the short circuit protection switch pulses the output to keep the current within acceptable limits. To protect the series switch from excessive dissipation a fold-back current limit is used.

In addition to short-circuit protection the PFC modules have over-voltage protection and over-

temperature protection. The over-voltage protection (OVP) circuits protect the load by shutting down the module if the output exceeds 415V. Once the output drops back down below 415V the module will resume operation. The module does not clamp the output and can't prevent external events from driving the output

Basic PFC Applications

NOTE: THE PFC MODULE REQUIRES THE USE OF A HOLD-UP CAPACITOR AND THE LOAD ENABLE SIGNAL FOR PROPER OPERATION. AN EMI FILTER IS ALSO RECOMMENDED. SEE THE TEXT FOR FURTHER INFORMATION.

The system block diagram shown in *Figure 24b* is a typical application of the PFC module. Input protection circuits, which are usually required, are not shown.

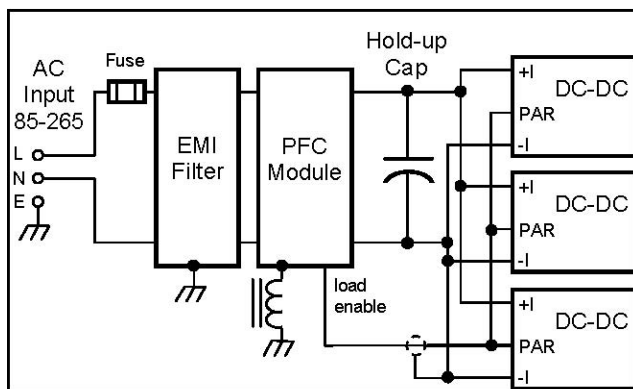

Figure 24b Typical PFC System Diagram. Input protection circuits are not shown.

Fusing

The AC power source must be fused; either on the system board, as shown in *Figure 24b*, or at the power source. An 8A, 250VAC, AGC type line fuse is recommended for the PFC-600 and PFC-1000 modules. If you are relying on the power source fuse it must be rated at 8A or less. Systems with multiple PFC modules must use an individual fuse for each module.

above the OVP level. The over-temperature protection (OTP) circuits monitor the baseplate temperatures internal to the module. If the baseplate temperature exceeds 105°C the module will shut down. Hysteresis in the OTP circuit forces the module to cool down slightly before automatically restarting.

EMI Filter

An input EMI filter is required to meet conducted emission specifications such as CISPR 22 and FCC. The filter protects the external world and the PFC module from each other's noise. It also presents a low AC source impedance to the PFC module. For safety and improved performance the case of the EMI filter should be earthed. A 6A, 250VAC filter is required for full power operation over the specified PFC module input range. As a rough estimate, the volume of the filter will be two to three times the volume of the PFC module. Systems that don't require the full power capability and/ or the full voltage range of the PFC module can use smaller filters. RO's PFC line filter, the HH1199-6, is designed for use with either the PFC-600 or the PFC-1000 modules. Other commercially available EMI filters such as the CORCOM's EQ and EU series are also suitable depending on the level of conducted emissions the user is required to meet.

The PFC modules have been verified to meet CISPR 22, level B emissions requirements with the HH1199-6 filter. EMI performance was tested with the filter and module mounted on RO's EB-PFC-24P evaluation board using a resistive load. The board and the load were placed in a shielded enclosure to minimize the possibility of radiated noise bypassing the EMI filter. CORCOM claims that both their 6EUP line filter and their 6EQ1 line filter also allow the module to meet CISPR 22 level B emissions requirements. The 6EQ1, however, requires an additional 1µF line-to-line capacitor at the PFC input. CORCOM tested their line filters using a modified EB-PFC-24P evaluation board.

Note: The EB-PFC-24P evaluation board uses a design trick to help minimize the conducted emissions. The baseplate of the module is tied to ground through a small choke. This reduces the common mode (CM) conducted emissions from the module by isolating the baseplate from the AC ground. This technique works best when the PFC is mounted to an individual heat sink such as RO #2006. To meet safety requirements the choke must use a wire with an effective diameter that is equivalent to or larger than 18 AWG. As there is no DC current flow an uncapped, high perm, magnetic material can be used for the core. The inductance should be on the order of 10 μ H to 20 μ H.

The EMI filter used should have at least 0.33 μ F of capacitance on its output (the PFC module side) in order to ensure that it presents low source impedance to the PFC module at the switching frequency of the module. If the EMI filter does not have sufficient capacitance, or if the EMI filter is remotely located, an agency recognized X capacitor should be added across the line at the input of the PFC module.

Input Protection

The PFC has no internal protection against transients or spikes on the input of the module. The designer must therefore add adequate protection externally to the module. Astrodyne recommends a two-prong approach that involves secondary and board levels of protection. (Primary protection is usually done at the building's AC panel or service entry point and is not discussed here.)

Secondary protection is placed on the line side of the EMI filter and consists of gas tubes or MOVs. It is intended to shunt high energy transients to ground before they reach the module. As there can be significant currents flowing through these devices they should be located close to the input connector to minimize inductive loop area and radiation effects. For additional spike suppression, install board level protection (MOVs or TVS diodes) on the load side of the EMI filter. Board level

protection is intended to shunt the energy that gets past the secondary protection to ground. The high AC impedance of the EMI filter will limit the current that flows through the board level protection devices.

The input protection circuits should be designed to keep the maximum voltage applied to the PFC modules below 500V.

Holdup Capacitors

The PFC modules require holdup capacitors for proper operation. The amount of holdup capacitance across the output of the PFC module is selected based on the required holdup time and the desired output ripple. Any amount of capacitance may be placed on the output with the following limitations: The minimum capacitance for $V_{in} > 150VAC$ is 220 μ F. The minimum capacitance for $V_{in} < 150VAC$ is 100 μ F. While there are no known limitations on the maximum holdup capacitance the designer should be aware that the startup time increases with increasing capacitance values.

The holdup time is the duration that the supply must be capable of running without any input power. A typical range of holdup times is 20ms to 50ms. The required capacitance is calculated by balancing the energy lost by the capacitor with the energy used by the load (including the DC-to-DC converter losses).

$$C = \frac{2 P T_{hold}}{V_1^2 - V_2^2}$$

Where:

- **C** is the required holdup capacitance in Farads
- **P** is the load power (including the DC-to-DC converter losses) in Watts is the holdup time in seconds
- **V1** is the output voltage of the PFC in Volts
- **V2** is the minimum input voltage of the DC-to-DC converters in Volts

The PFC output ripple is usually not a high priority for system designers. However, in low noise applications the ripple might be important. The post converters will typically attenuate the 120Hz (f is 2 times the line frequency) output ripple of the PFC by 60dB, or a factor of 1000. This means that a system with 12V of PFC ripple will have 12mV of 120Hz output ripple in addition to the normal ripple of the post converters. *Figure 24c* shows the typical PFC output ripple versus holdup capacitance and load power. This data applies to 120VAC line voltage. 220VAC systems will have slightly higher ripple.

When selecting capacitors to provide the required holdup capacitance, pay attention to the ripple current rating of the capacitors. *Figure 24d* shows the typical ripple current that the holdup capacitor (or capacitor bank) will see. Also pay attention to the voltage rating of the capacitors, and the minimum capacitance over the operating temperature range of the supply. Most capacitors, especially electrolytics, will lose a significant percentage of their capacity at low temperatures.

Load Enable Signal

The PFC modules utilize fold-back current limiting to safely and quickly start-up into large capacitive loads. Since non-capacitive loads can prevent the PFC from starting properly, the PFC modules have a load enable circuit that disables the load until the PFC can supply the rated current. ***The load enable must be used in all applications.***

The PFC load enable circuit interfaces with the on/ off control input of the load. It is designed for loads that are disabled when the control input is pulled low with respect to the -OUT pin of the PFC. Other loads may require some interface or “glue” circuitry to work properly with the PFC. AP-23 provides more information. On turn-on, the LD ENA pin is active low until the PFC output rises above 345VDC. It then becomes an open drain. On turn-off the LD ENA pin

remains an open drain until the output drops below 220VDC. The LD ENA pin is capable of sinking up to 90mA continuously and has a maximum voltage rating of 60V with respect to the -OUT pin of the PFC. Its active low voltage is less than 0.3V when sinking 10mA.

In systems using MicroVerter modules the load enable connection to the parallel pin must either be shielded or diode isolated to prevent noise from affecting the operation of the module(s). A coax cable can be used with the shield tied to the -Vin of the modules. In a PC board layout this connection can be shielded by using a separate layer and placing the -Vin connection of the modules between it and the modules. An example of diode isolation is shown in *Figure 24f*.

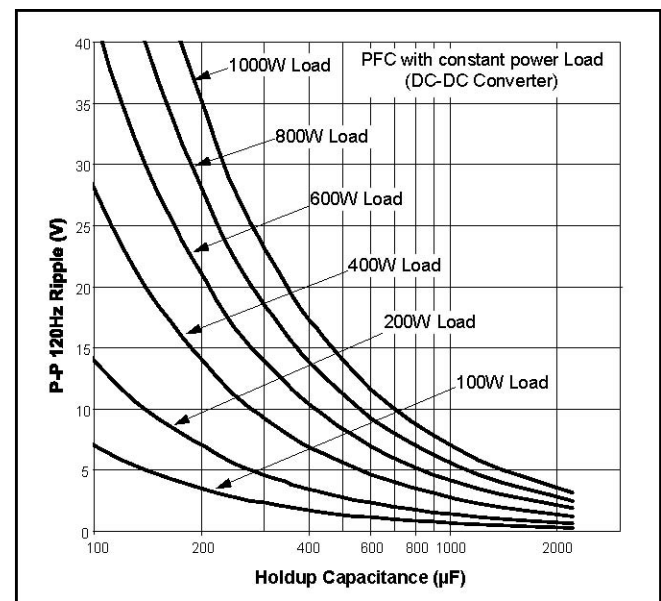

Figure 24c Typical PFC output ripple vs. capacitance (120VAC, 60Hz line). See text for restrictions.

Do not use a pull up resistor on the load enable signal if it is directly connected to the parallel pin of MicroVerter converters. Applying a voltage >6V to the parallel pin of the µV300 series of DC-DC converters will damage the modules.

Additional information on interfacing with the Load Enable signal can be found in AP-23

DC OK Signal

The DC OK signal monitors the 380VDC output of the PFC and provides a power fail warning that the DC output or AC input is going away. On turn-on the DC OK pin is active low until the PFC output rises above 360VDC. It then becomes an open drain. On turn-off the LD ENA pin remains an open drain until the output drops below 350VDC. The DC OK pin is capable of sinking up to 90mA continuously and has a maximum voltage rating of 60V with respect to the -OUT pin of the PFC. Its active low voltage is less than 0.3V when sinking 10mA.

Vaux Output

The Vaux output is a 14V, 10mA max. auxiliary output referenced to the -OUT of the PFC. It is intended to be used as a bias supply for pull-up resistors and opto-isolators associated with the LD ENA and DC OK signals. The Vaux supply is powered by the switching action of the PFC's main boost circuit (See *Figure 24a*). Because of this the supply may exhibit significant 120Hz (with a 60Hz line) ripple during normal operation and may even drop-out when the main output is unloaded. Astrodyne recommends a hold-up capacitor on the Vaux pin to minimize any problems resulting from this behavior. A typical Vaux hold-up capacitor is a 47µF, 25V electrolytic. The Vaux output is short circuit protected.

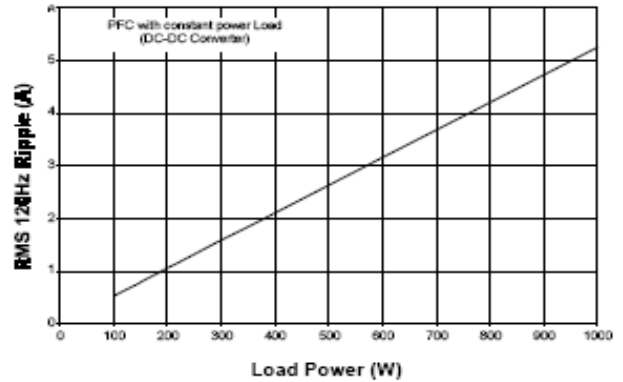

Figure 24d Typical Hold up Cap Ripple Current vs Load Power (60Hz Line)

Multiple PFC Systems

When multiple PFC modules are used to drive paralleled MicroVerter modules the bridge rectifiers in the PFC modules will not share current equally. This is because the paralleled MicroVerter modules require that their -IN pins be tied together. When the PFC modules are connected to both the -IN buss of the MicroVerter modules and the AC input bus the lower diodes in the rectifier bridges are effectively in parallel. *Figure 24e* shows a simplified diagram of the resulting circuit. In an ideal diode, the diode current is an exponential function of the applied voltage and diode threshold voltage as shown in the following equation.

$$I_D = I_S \times e^{(V_D/V_{KT})}$$

When diodes are paralleled, small differences in V_{KT} will result in large differences in diode currents. The end result is that almost all of the return current from the MicroVerter modules will flow through one of the PFC modules.

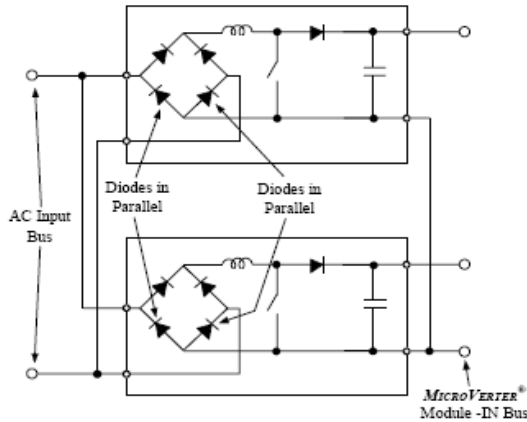

Figure 24e Connecting multiple PFCs to the AC input bus and the MICROVERTER[®] -IN bus parallels the lower diodes in the rectifier bridges.

Figure 24f shows a simple, cost effective technique of forcing the paralleled PFC rectifiers to properly share the return current. This approach places a resistor, R_s , in series with the output return pin of each PFC module. The resistor improves the current sharing by reducing the sensitivity of the diode current to differences in V_{kT} . The recommended parameters for R_s are 0.25Ω , 1W.

The approach shown in Figure 24f ensures PFC module load sharing by connecting the same number of output modules to each PFC module. The fact that the output modules are load sharing will force the PFC modules to load share. This approach can even be extended to provide $N+1$ redundancy.

Possible Applications

AC front end for 300V input DC-DC Converters -The PFC module converts AC to 380V to drive the 300V input DC-DC converters.

Power Factor Correction -The PFC provides power factor correction to meet the harmonic distortion requirements of IEC1000-3-2. The PFC can be used to provide power factor correction for switching power supplies

Universal Input -The PFC-600 can provide universal AC input from 85-265VAC for DC-DC converters or for switching power supplies.

Custom Power Supplies -The PFC can be used in conjunction with a variety of DC-DC converter output modules to create a custom power supply with a very short design time.

Precautions

Hazardous Voltages -When implementing the PFC there may be exposed AC input voltage and exposed 380VDC voltage. Care should be taken to provide insulation, protective covers, and warning labels.

PFC module is not isolated -The output of the PFC module is not electrically isolated from the input. Do not connect the output or status pins to earth ground either intentionally or accidentally (e.g. with a scope probe ground lead) unless proper precautions have been taken. Consider using an isolation transformer for testing purposes.

EMI Filter -An EMI filter is recommended on the line side of the PFC module to filter the 140KHZ switching of the PFC boost converter.

Hold Up Cap -A hold up cap must be used on the load side of the PFC for proper operation. The holdup capacitor maintains an acceptable ripple voltage for the load and provides hold up time during power outages.

Shielding of the Load Enable Signal -The connection between the load enable signal and the parallel on/off pin(s) of the MicroVerter DC-DC converters must be shielded or diode isolated to keep noise off of the parallel pin(s). A coax cable with the shield tied to -Vin of the DC-DC modules or a separate layer of a multi-layer PC board will provide adequate shielding.

Fuse the Input - The supply should have an 8A, 250VAC fuse between the AC source and the PFC module.

Related Topics

AP-3 Input Ripple Measurement and Filtering
AP-13 Paralleling with Current Sharing and n+m Redundancy

AP-18 Board Layout Considerations
AP-19 Hole Dimensions and Socket Information
AP-23 PFC Load Restrictions during Startup

Figure 24f a simple, cost effective approach to a multiple PFC system

