



MEGAVERTER®

520 WATT DC-DC CONVERTER MODEL MV380-26 DATA SHEET

Distributed Power in Telecom, Industrial Control, Wireless, & Computer Applications

INPUT: 380VDC • OUTPUT: 26VDC @ 20.0A • 520 WATTS



Size: 2.4 x 4.6 x 0.5 inches

DESCRIPTION

MEGAVERTER DC-DC converters are high density, feature rich modules packaged in the industry standard “full brick” size (2.4 x 4.6 x 0.5 inches) for circuit board mounting. They are used where large blocks of DC power are required. The MV380-26 is designed for use with a PFC front end and provides up to 520 Watts of low noise, 26Vdc power from a universal ac line.

FEATURES

- High Efficiency: 88%
- -40 to +100°C Operation
- Constant Frequency
- Trim Range: 18V to 30V
- Non-Shutdown Over Voltage Protection
- Remote Sense
- High Power Density: 94 W/cu. in.
- Low Noise
- Encapsulated
- Parallelable with Current Sharing for n+m Redundancy
- 105°C Over Temperature Protection
- Safety Agency Compliant

MODEL SELECTION

Model Number	Input Voltage (Vdc)	Output Voltage (Vdc)	Output Current (A)
MV380-26	360-400	26	20.0

Application Notes and Evaluation Boards are Available

MEGAVERTER® DC-DC Converter

MV380-26

ELECTRICAL SPECIFICATIONS (continued)

ISOLATION PARAMETERS	MIN	TYP	MAX	UNITS	CONDITIONS
Input/Output Isolation			4500	Vdc	
Input/Baseplate Isolation			2500	Vdc	
Output/Baseplate Isolation			500	Vdc	
Input-to-Output Capacitance			4300	pF	Case Floating
Input-to-Output Resistance	10			M Ohms	

MECHANICAL PARAMETERS	MIN	TYP	MAX	UNITS	CONDITIONS
Weight		230 (7.4)		g (oz.)	
Size		0.5 x 2.4 x 4.6		Inches	See Outline Drawing
Thermal Resistance, Case-to-Ambient		3.3		°C/W	Case Temperature = 100 °C

FEATURE PARAMETERS	MIN	TYP	MAX	UNITS	CONDITIONS
Power Sharing Accuracy			±5	%F.L.	10 to 100% Full Load (F.L.)
Trim Range	18**		30	Vdc	**200mA min. load for Vdc<20V
Remote Sense Compensation			0.5	Vdc	
Over Voltage Protection (Non-Shutdown, Auto. Recovery)	30		36	Vdc	25 °C Case
Over Temperature Shut-down	+100	+105	+110	°C	Case Temperature
Turn-On Time		600		msec	F.L., V _{out} within 1% of Steady State
Enable *					
Logic Off Threshold	0.8			V	V _{out} = 0
Enable Current (Logic Off)			1.0	mA	@V _{enable} = 0 V
Logic On Threshold			2.4	V	
Turn-On Time			2.0	msec	F.L., V _{out} within 1% of Steady State

* An open collector connection or equivalent is recommended for on/off control.

TRIM CIRCUIT CONFIGURATIONS

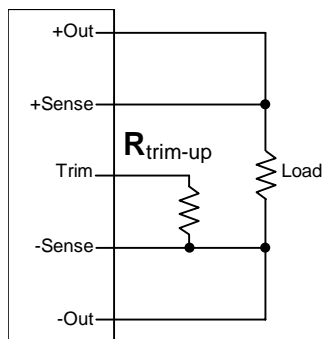

Trim Up

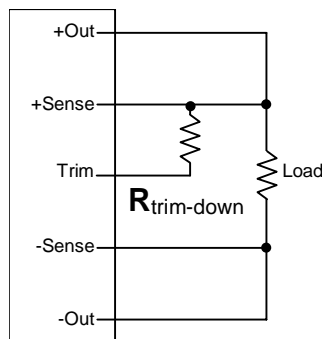

Trim Down

TRIM RESISTOR CALCULATIONS

$$R_{\text{trim-up}} = \frac{32.76 - 2.67 \times \Delta V_o}{\Delta V_o} \text{ kohms}$$

$$R_{\text{trim-down}} = \frac{308.0 - 15.78 \times \Delta V_o}{\Delta V_o} \text{ kohms}$$

ΔV_o = Desired Output Voltage Change (Volts)

$R_{\text{trim-up}}$ = External Resistor Value to Increase V_o

$R_{\text{trim-down}}$ = External Resistor Value to Decrease V_o

MEGAVERTER® DC-DC Converter

MV380-26

ABSOLUTE MAXIMUM RATINGS

Exceeding absolute maximum ratings may cause permanent damage and may reduce reliability.

PARAMETER	MIN	MAX	UNITS	CONDITIONS
Input Voltage (+In to -In)	-0.3	420	Vdc	
Enable Voltage (Enable to -In)	-0.3	6.0	Vdc	
Parallel Pin Voltage (Parallel Pin to -In)	-0.3	5.0	Vdc	
Storage Temperature	-55	+125	°C	
Operating Temperature	-40	+100	°C	Baseplate
Soldering Temperature (Wave Solder)		260	°C	< 5 sec.
Soldering Temperature (Hand Solder)		390	°C	< 7 sec.

ELECTRICAL SPECIFICATIONS

Electrical specifications apply over the entire range of input voltage, output current, and temperature unless indicated.

INPUT PARAMETERS	MIN	TYP	MAX	UNITS	CONDITIONS
Input Voltage	360	380	400	Vdc	
Maximum Input Current			2.5	A	See Input Characteristic Curve
Input Ripple Rejection		60		dB	@120 Hz

OUTPUT PARAMETERS	MIN	TYP	MAX	UNITS	CONDITIONS
Voltage Set Point	25.75	26	26.25	Vdc	380 V _{in} , 25°C, Full Load
Load Regulation		0.3	0.6	%	0 A to Full Load
Line Regulation		0.02	0.1	%	Over V _{in} Range
Voltage Drift w/Temperature			0.02	%/°C	-40 to +100 °C
Ripple		1	2	%Vp-p	5 Hz to 20 MHz
Rated Current	0		20.0	A	
Output Power			520	W	
Current Limit Inception	115	120	130	% F.L.	V _{out} = 95% V _{out} nominal
Short Circuit Current			150	% F.L.	V _{out} = 250 mV
Transient Response Peak Deviation (0.5A/μsec slew rate)		5		% V _{out}	Load Change from 25% to 75% to 25% Full Load
Transient Response Settling Time (0.5 A/μsec slew rate)		100		μsec	V _{out} within 1% V _{out} nominal
Efficiency		88		%	V _{in} = 380 V, Full Load, 70 °C Case
External Load Capacitance	0		3,300	μF	

Astrodyne Corporation PH: 800-823-8082 FX: 508-339-0375 Email: sales@astrodyne.com

www.astrodyne.com www.roassoc.com

MEGAVERTER[®] DC-DC Converter

MV380-26

Efficiency

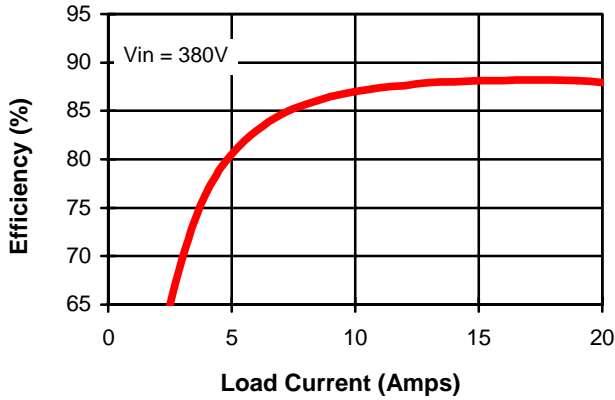

Transient Response

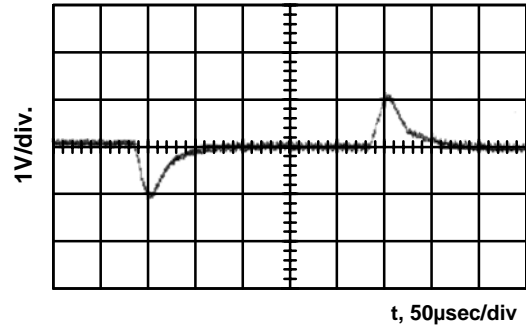

$I_{out} = 5A - 15A - 5A$
 Current Slew Rate = $0.5A/\mu\text{sec}$

Outline Drawing

